

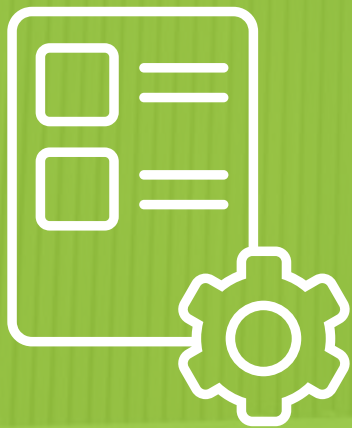

AUSTRALIA'S #1 COMPOSITE DECKING

CLADDING INSTALLATION GUIDE



WWW.BRITEDCKING.COM.AU



THANK YOU

FOR CHOOSING OUR COMPOSITE PRODUCTS!

Compliance with Local Building Codes

Before You Begin: Prior to initiating the installation of any composite cladding, it is imperative that you thoroughly review and adhere to local building codes and regulations. Failure to do so may result in non-compliance and potential legal issues. The following guidelines are provided for informational purposes only and are not intended to replace professional advice

Safety Precautions

Your safety is of utmost importance during the cladding installation process. Whenever you engage in a construction project, always don appropriate safety equipment, including safety glasses, safety boots, gloves, dust masks, long sleeves, and appropriate pants.

Essential Tools

To guarantee a successful installation, it is essential to select the correct woodworking tools. These may comprise a standard power drill or impact drill. Additionally:

- Verify that all blades are sharp and furnished with carbide tips to ensure precise and clean cuts.
- Employ solely standard stainless steel or approved coated screws and nails for the installation process.

Wall Surface Preparation

A well-prepared wall surface is crucial for the correct installation of briedeck's cladding. Follow these steps:

- The wall surface must be clean, smooth, flat, and structurally sound.
- Prior to installation, consult local building codes for any specific requirements.
- Avoid installing Brite Decking cladding boards over existing cladding boards.
- Do not directly install cladding boards onto a flat surface. Ensure they are supported by a code-compliant substructure.

Protection Against Excessive Heat

Pay close attention to the possibility of excessive heat originating from external sources, including fire or reflected sunlight from energy-efficient window products featuring Low-E glass, as it can potentially harm Brite Decking products.

To Address Low-E Glass Concerns: Individuals with concerns about potential damage resulting from Low-E glass should reach out to the manufacturer of such products for guidance on mitigating or eradicating the adverse effects of reflected sunlight.

Screw Selection and Installation Guidelines:

Proper Screw Selection: We strongly recommend using standard stainless steel or approved coated deck screws and nails for your cladding installation requirements.

To ensure a secure cladding installation, adhere to the following guidelines when selecting and installing screws:

- **Choose Appropriate Screws:** Select screws explicitly designed for use with composite cladding material, ensuring they possess the capability to effectively penetrate the surface into which the subframe will be anchored. Surface types may include concrete, brick Gyprock, wood or battens.

- Pre-Installation Testing:** Before proceeding with the installation, it is advisable to conduct a pre-installation test by driving the screws into a scrap piece of board. This step aims to prevent any undesirable surface mushrooming or bulging around the screw head. If such issues arise during testing, consider altering the screw type or pre-drilling the board.

Screw Length: Ensure that all screws utilized are of an adequate length to penetrate the joist by a minimum of 20mm. This guarantees a robust and secure attachment.

Face-Fastening Technique: When opting for face-fastening, consistently drive the screws at a 90-degree angle to the board surface. This approach yields optimal results, maintaining the structural integrity of the cladding.

By adhering to these screw selection and installation guidelines, you can achieve a reliable and safe cladding installation that adheres to best practices and ensures long-lasting performance.

Specification

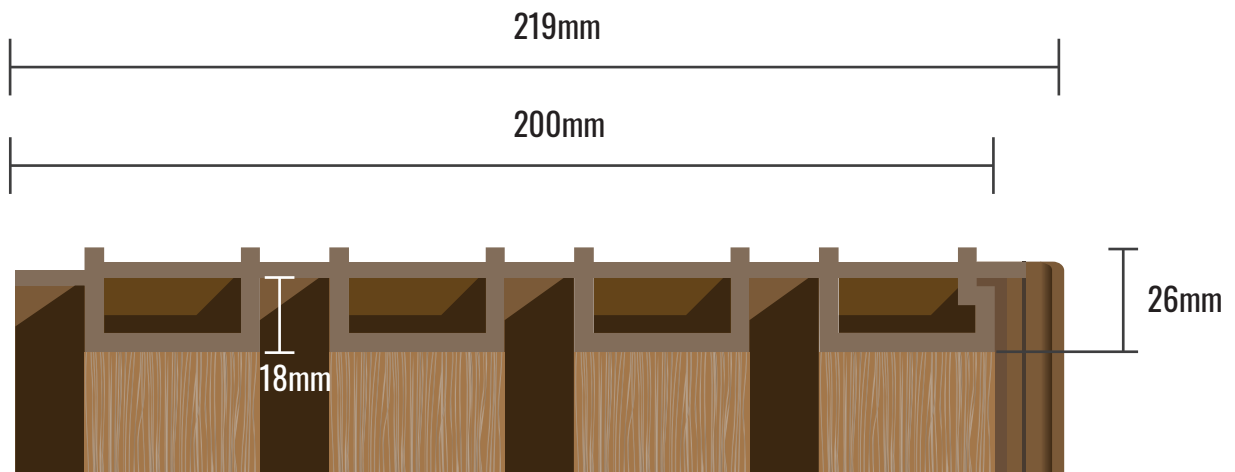

VISIBLE WIDTH	THICKNESS	SPAN	LENGTH	BOARD WEIGHT	WEIGHT PER SQM
200mm	26mm	400 - 500mm	5400mm	15.5kg	14.5kg

Required Accessories

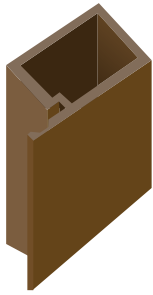

Brite Decking Starter Trim



Brite Decking Crossroad Trim



Brite Decking Corner Trim

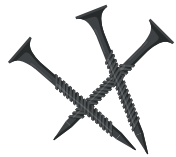

25mm Screws
Screws are not included on your order

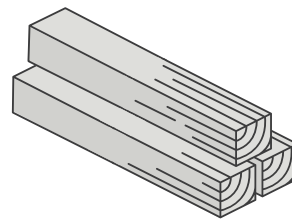

Suitable Joist / Battens
Also available: Brite Decking's Composite Joist
57mm x 32mm x 2.2m

Horizontal Installation

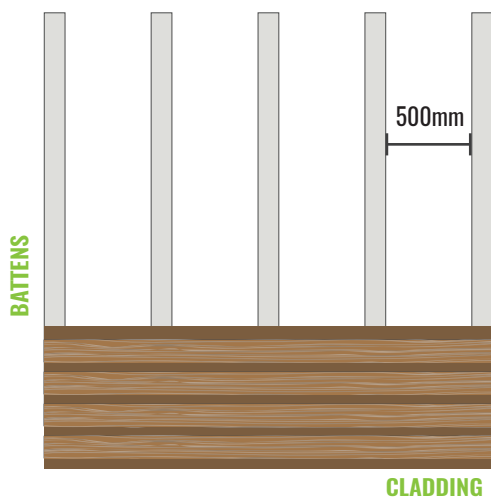

Vertical Installation

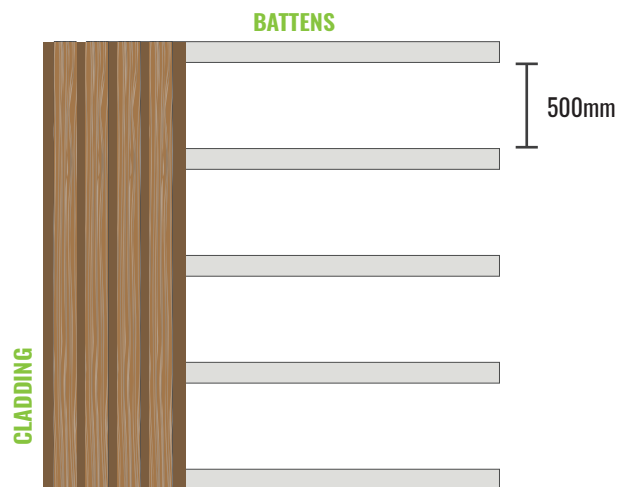

Cladding Installation Guidelines for Different Wall Sides

When installing cladding on various wall sides, it's crucial to follow these specific guidelines for each side:

Wall Side A: Cladding between the Trim and the Inside Corner

Wall Side B: Cladding between the Inside Corner & the Outside Corner Trim

Wall Side C: Cladding between the Outside Corner Trim & the Trim

Minimum Floor Clearance: Ensure that a minimum clearance of 40mm is maintained between the lowest batten and the floor. This clearance allows for proper ventilation and avoids potential moisture-related issues.

Minimum Ceiling Clearance: Maintain a minimum clearance of 10mm between the ceiling and the top of the battens. This clearance is essential to accommodate any potential expansion or contraction of the cladding material due to temperature and humidity changes.

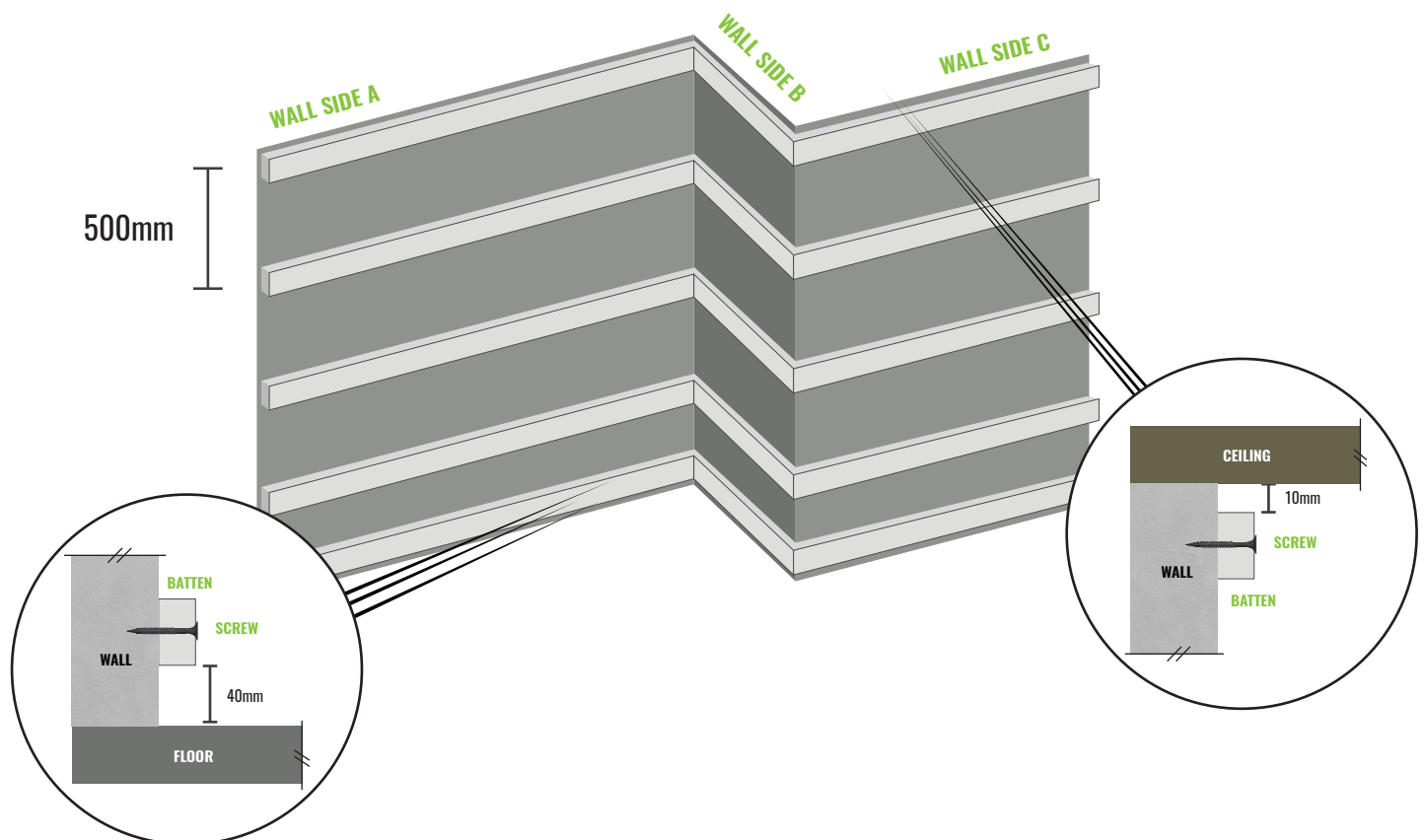

Trim and Cladding Installation

Secure the Starter Trim onto the batten using screws

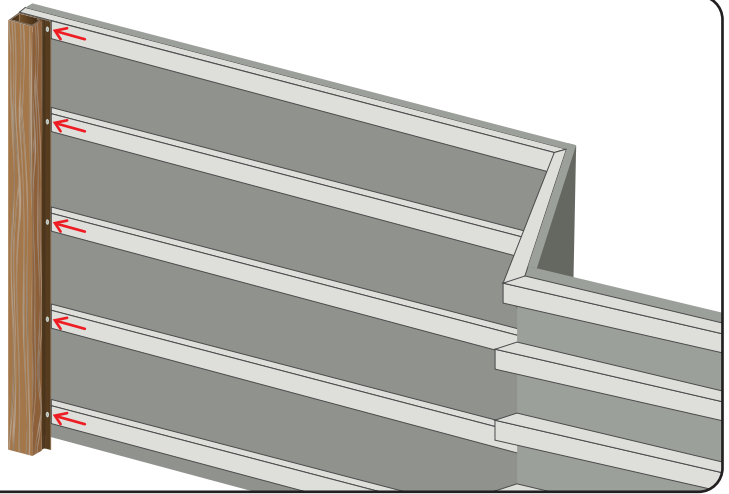

Ensure a minimum clearance of 20mm between the ceiling and the boards

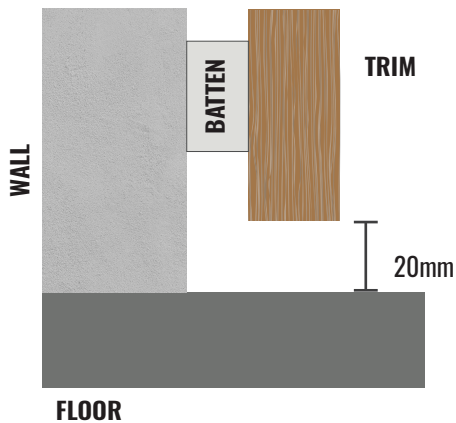
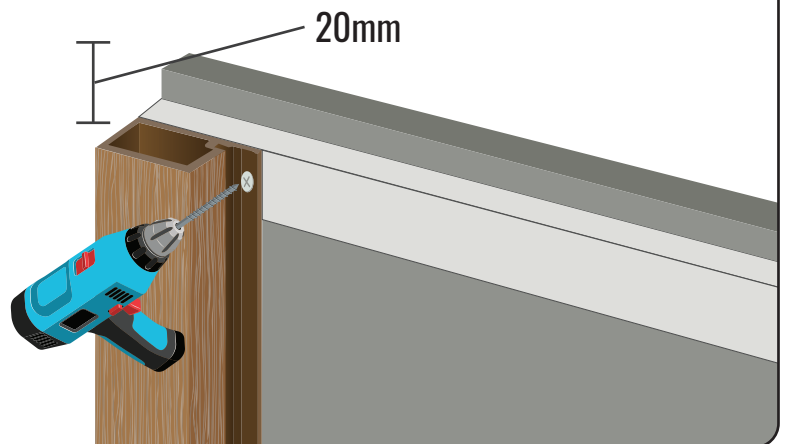

A minimum clearance of 20mm needs to be left between the trims and the floor, as shown the picture.

Begin by placing the first cladding board into the trim.

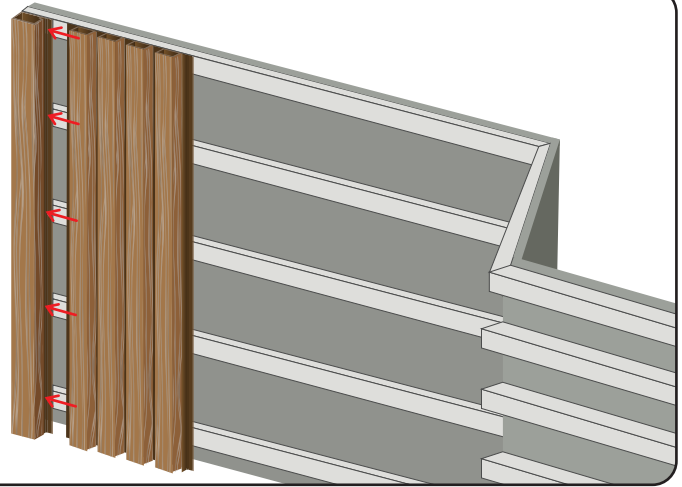

Secure the cladding to the batten using screws.

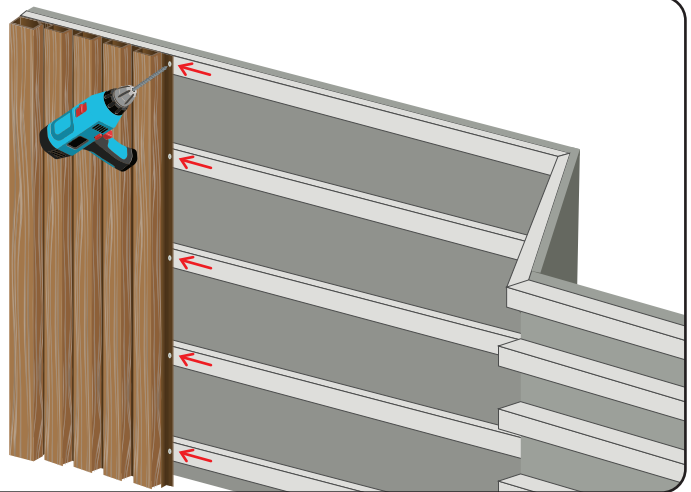

Position the second cladding board over the first one and fasten it to the batten with screws.

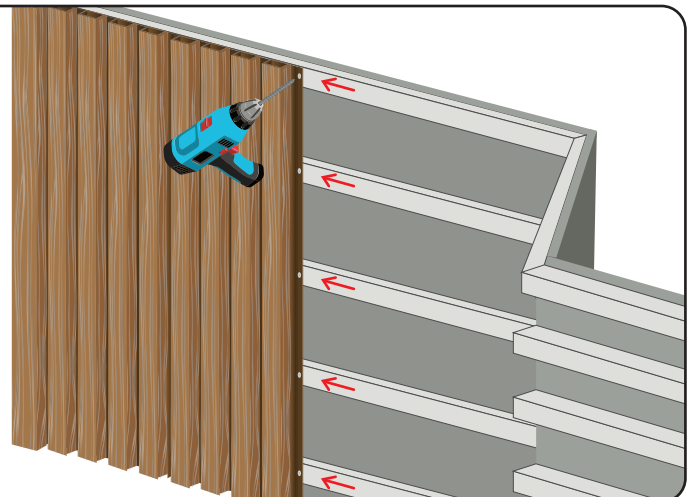

When you reach the last cladding board, and the installation is approaching the inside corner, take precise measurements and document the distance. Subsequently, cut the board according to either Figure A or B and securely attach it to the batten.

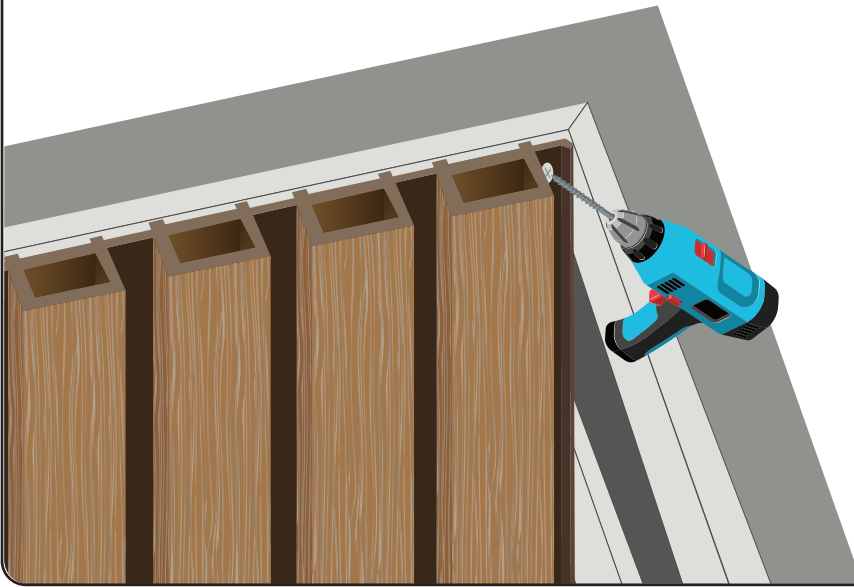

Inside Corner

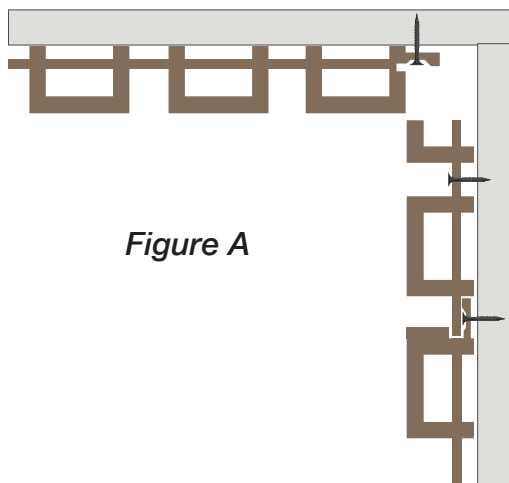

Figure A

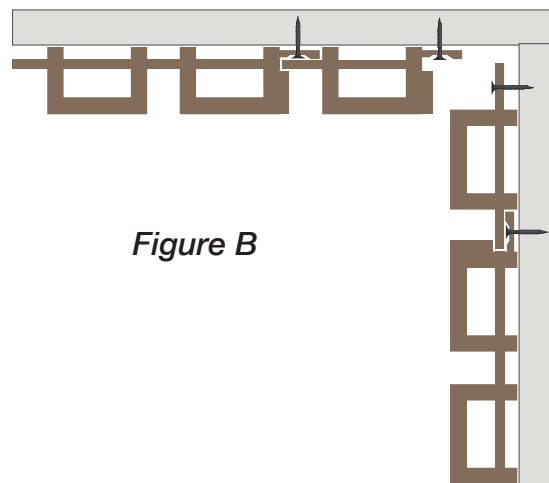
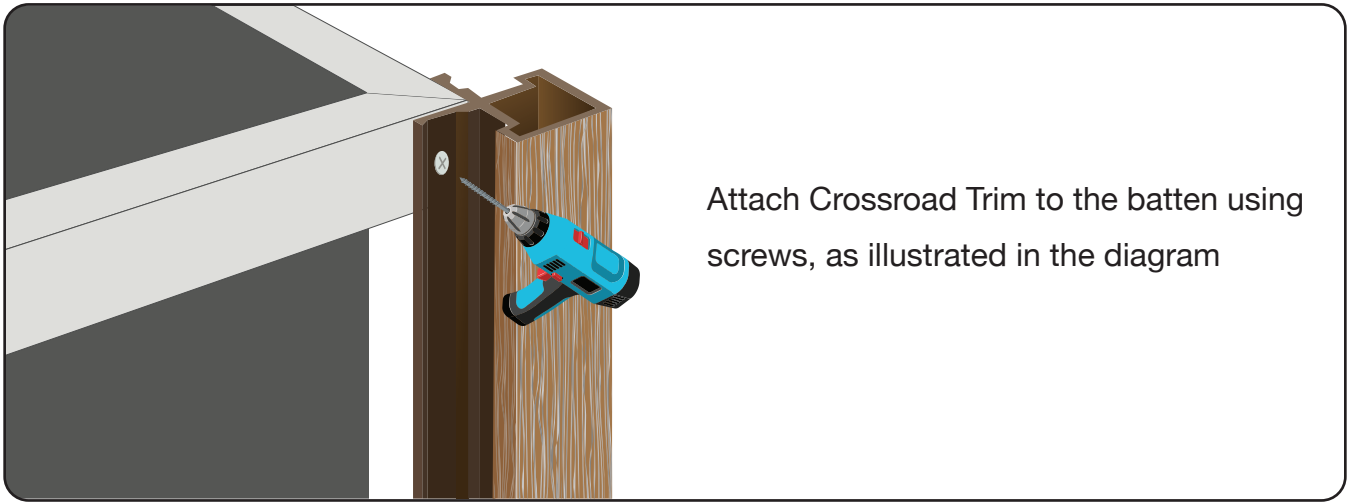

Figure B



Place the second cladding board over the first board and secure it to the batten with screws, repeating this process as indicated in Figure C & D

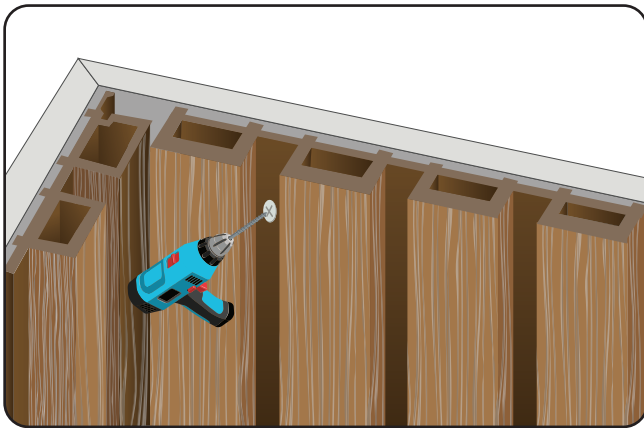

Figure C

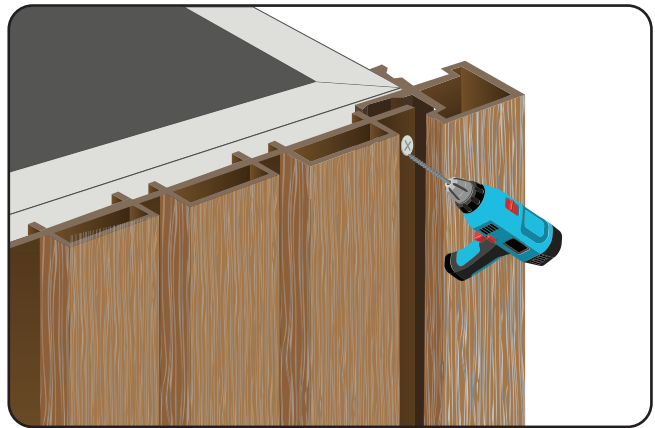
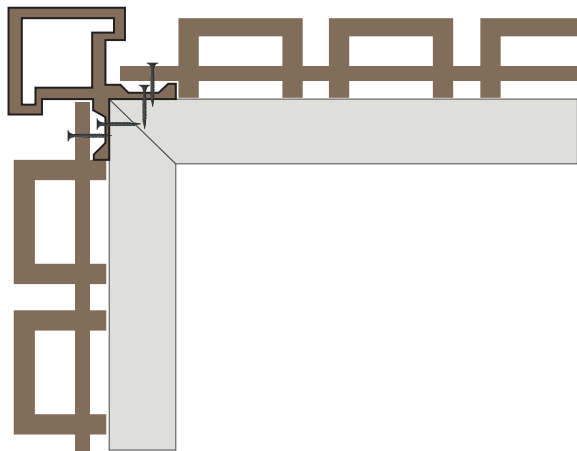

Figure D

Outside Corner



Begin the next section by inserting the first cladding board into Crossroad Trim, securing it to the batten with screws. Follow by placing the second board over the first and securing it in the same manner and repeat these steps.

For the final cladding board, measure, cut, and insert trim A, ensuring it is securely fixed to the batten using screws.

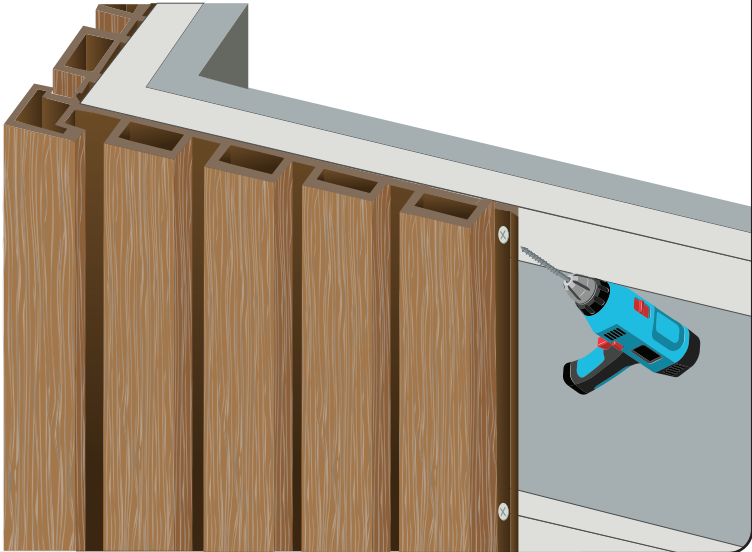

Upon completing the installation, review the final appearance to ensure a satisfactory result.

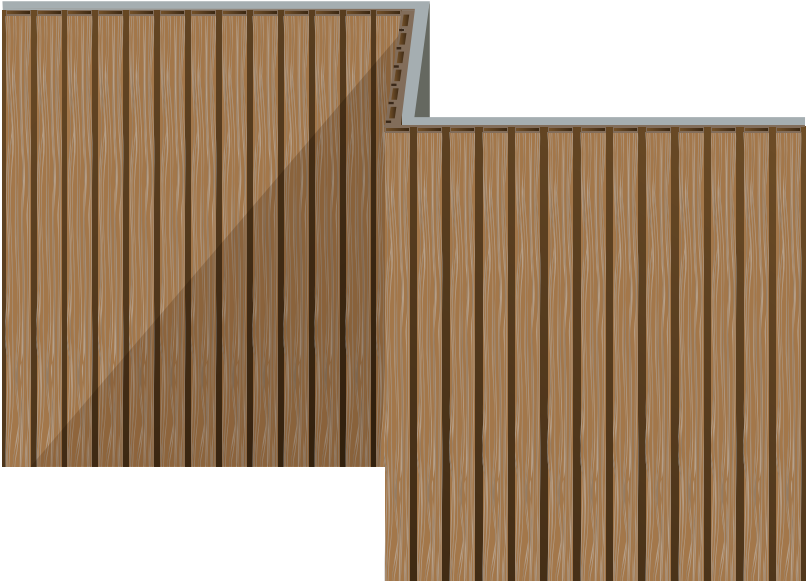

Horizontal Installation

Slide and fix the second cladding board

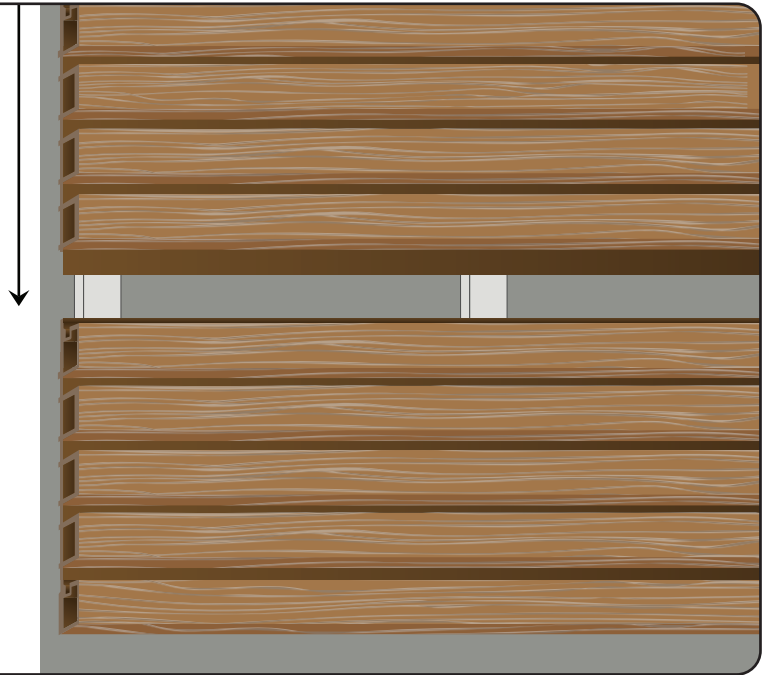

When it comes to finishing your Cladding project, you may wish to use a Corner Trim along the edges of your installation for a flush finish that hides any hollow ends.

Measure the area you wish to cover with the Corner Trim and cut the Trim to size. Pre-drill the Corner Trim and fix securely every 300mm along the length using appropriate screws. When joining one Trim end to another, a minimum gap of 2mm should be left between both ends.

